

# Model Q-8 Loudspeaker

## Offering high sensitivity & power handling capabilities

The Model Q-8 is more robust than our compact Soundsphere loudspeakers models, offering greater sensitivity and power-handling capability. The Q-8 was designed to provide clear voice announcements and high-fidelity foreground and background music for applications such as restaurants, courtrooms, churches, shopping centers and airports.

The Q-8 offers Soundsphere's trademark hemispherical coverage pattern and is distinguished by its high sensitivity (94dB 1W/1m) and high power handling capability (100 watts RMS). The Q-8 is available for either surface or hanging mounts, in both standard and custom colors.



### Q-8 Technical Data

 [Download the Model Q-8 Spec Sheet \(365k\)](#)  
[Get the FREE Acrobat Reader](#)

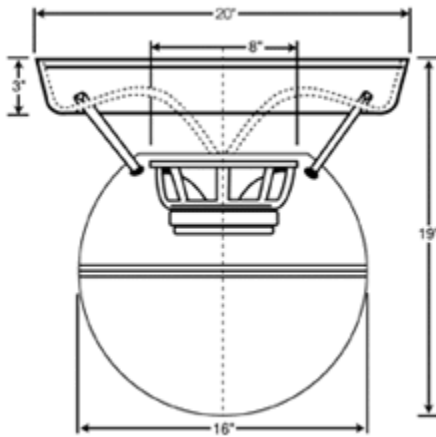

### MODEL Q-8 APPLICATIONS:

- Restaurants
- Bars & Nightclubs
- Hotel Lobbies & Atriums
- Factories
- Courtrooms
- Gymnasiums
- Educational Facilities
- Churches
- Retail Stores
- Shopping Centers
- Airports

*And applications where clear voice announcements and high-fidelity music are required.*

MODEL Q-8 SPECIFICATIONS:	
<b>Sensitivity:</b>	94dB SPL; 1 Watt/1 meter
<b>Maximum SPL:</b>	114dB SPL; 1 meter
<b>Power Handling:</b>	100 Watts RMS
<b>Frequency Response:</b>	55Hz to 17kHz ± 6dB
<b>Coverage:</b>	180° vertical 360° horizontal
<b>Rated Impedance:</b>	8 ohms
<b>Weight:</b>	22 lbs. (10 kg)
<b>Size:</b>	Height: 19" (485mm) Sphere Diameter: 16" (406mm) Reflector Diameter: 20" (508mm)
<b>Driver:</b>	Coaxial: 8" LF, 1" dome HF

	Constructed of inorganic materials impervious to environmental contaminants (weather, ozone, UV, chlorine, salt, etc.)
<b>Material:</b>	Enclosure and reflector are fiberglass with gelcoat finish; rust-resistant hardware
<b>MODEL Q-8 SAMPLE INSTALLATIONS:</b>	
<b>Manufacturing Plants:</b> <a href="#">1</a> // <a href="#">2</a>	
<a href="#">Church</a>	
<a href="#">Courtroom</a>	
<a href="#">Health Club</a>	
<a href="#">Shopping Mall</a>	

## Model Q-8 Accessories

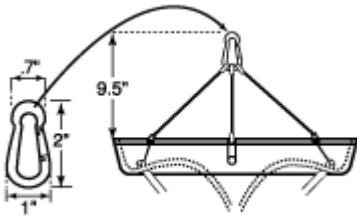

**Hanging Kit – Order No. HK**

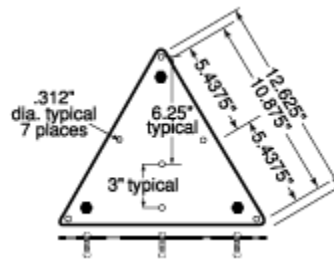

**Mounting Bracket – Order No. MBM**

### Line Matching Transformer – Order No. TX100

The Model TX100 is a 100 watt line matching transformer for the Model Q-8 with taps for 25V, 70V, and 100V constant voltage systems. The Model TX100 is factory-mounted in the reflector of the Model Q-8, and its low profile permits the use of the Q8HK hanging kit or the Q8MB mounting bracket. Connection to system wiring is via color-coded flying leads. Available taps: 25V-25W, 12.5W; 70V and 100V-100W, 50W, 25W, 12.5W.